



HL1919 Touch-dim series Linear Light

SC-HL1919-024-24V-01W
SC-HL1919-024-24V-01NW
SC-HL1919-024-24V-01WW

Description

LED linear light is exclusively designed for designer and architect with imagination and personal style. LED linear light adopt premium aluminum profile, different dimension and size, easy to install. 3 types installation method: ceiling mounted type, suspended type and embedded type, and different customized dimensions are also acceptable, which can meet installation requirement of different fields and occasions.

Features

1. Color: cool white(5000-6500K), natural white(3700-4500K)
warm white(2700-3200K), other available.
2. Beam angle: 110 Degree
3. Saving energy: 50%
4. Life span more than 50,000Hrs
5. IP code: IP40
6. Standard warranty: 3years
7. Follow CE Certified.



Technical Parameter

Input Voltage: DC 24V
LED type: 2835 SMD LED
Input Power: 24W
Reflector: Milky cover

Applications

- Hotels
- Conference/Meeting rooms
- Factories and offices
- Commercial purposes
- Residential / Institution buildings
- Schools, colleges, universities and hospitals
- Places which needs energy saving and high color rendering index lighting.





Specifications

Model #	CCT	LED Type	Lumen(lm) (±10%)	CRI	Beam angle	Power(W) (±10%)	Voltage (V)	PF	Weight (Kg)
SC-HL1919-024-24V-01W	5000-6500K	2835	2012lm	>80	110°	24W	DC 24V	/	0.53
SC-HL1919-024-24V-01NW	3700-4500K		2115lm	>80	110°	24W			
SC-HL1919-024-24V-01WW	2700-3200K		1701lm	>80	110°	24W			

Product packaging information:

1. Net weight: 0.53 kg
2. Gross weight/Carton: 16.7kg
3. Packing size: 1260X280X220mm
4. 1pcs per inner box,30 inner boxes per carton.

All dimension units are millimeter.

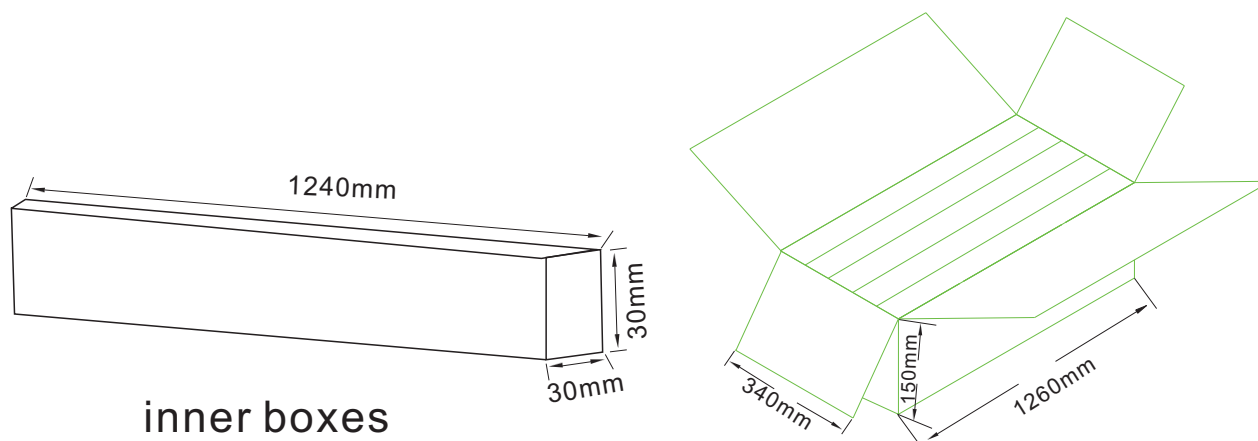

Dimensions (Unit: mm/inch)

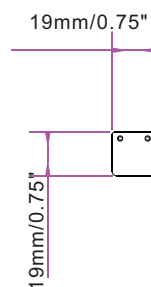
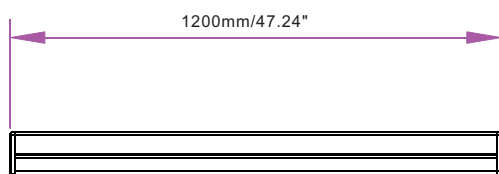

All dimension tolerance is $\pm 0.5\text{mm}$ unless otherwise noted.



Electrical Connection

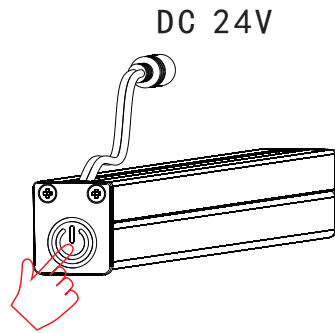

How to fix

Embedded Installation Diagram

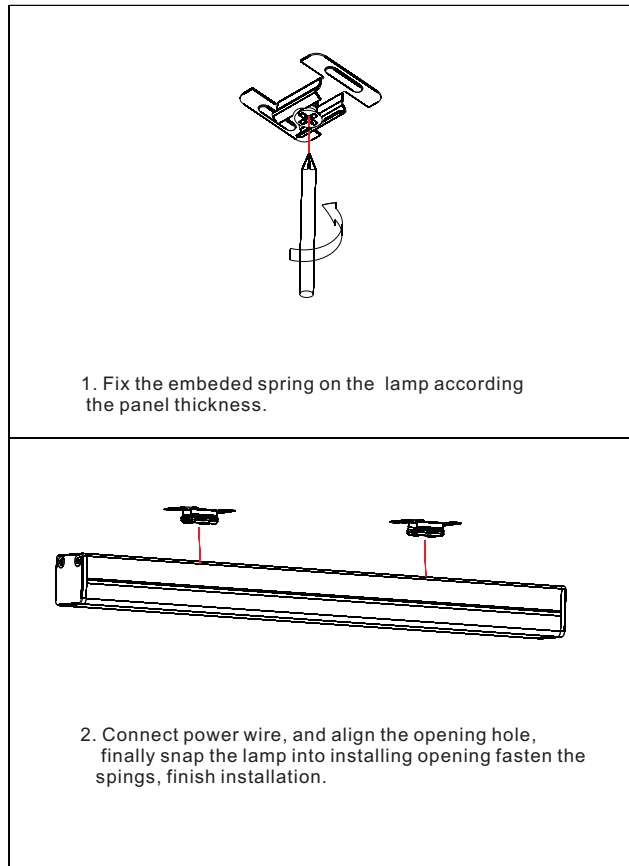

! How to dim

1. Switch function: Let it power on or off just need to touch by your finger.
2. Dimming function: It needs 4 seconds to make the lighting brighter and darker (as long as the brightness can satisfy you, you can stop touching), it won't change until the brightness reaches the highest or lowest point.
3. Memory function: it can automatically remember the last brightness; it means that the brightness can keep the previous condition by touching way after you turned the light off.